

# Max Wide Tube Tilt Trailer

14,000 - 16,000 - 20,000 GVW

Partial Tilt



Manufactured by:

[www.behnkeenterprises.com](http://www.behnkeenterprises.com)

Ph. (563)744-3246

Behnke Enterprises, Inc. • 800 Ninth Ave. NW • Farley, IA 52046

# Max Wide Tube Tilt Trailer

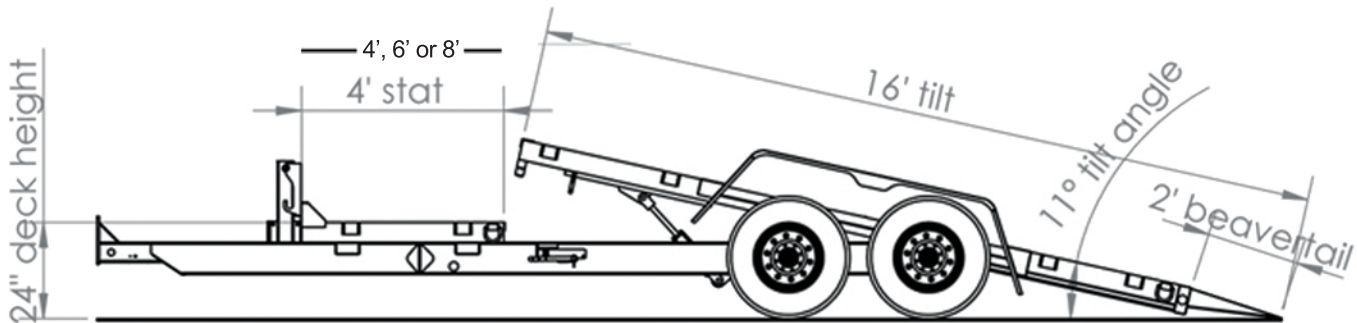

## Max Width Tilt Trailer

14,000 GVW - 16,000 GVW - 20,000 lb. GVW

Model	GVW	Tilt	Stationary	Btwn Fender	Dexter Axles	Tire
TBCT2014ET-MW	14,000	16'	4'	83"	(2) 7,000 lb. Torflex	ST235-80R-16E
TBCT2214ET-MW	14,000	16'	6'	83"	(2) 7,000 lb. Torflex	ST235-80R-16E
TBCT2414ET-MW	14,000	16'	8'	83"	(2) 7,000 lb. Torflex	ST235-80R-16E
TBCT2016ET-MW	16,000	16'	4'	83"	(2) 8,000 lb. Torflex	215-75R-17.5
TBCT2216ET-MW	16,000	16'	6'	83"	(2) 8,000 lb. Torflex	215-75R-17.5
TBCT2416ET-MW	16,000	16'	8'	83"	(2) 8,000 lb. Torflex	215-75R-17.5
TBCT2020ET-MW	20,000	16'	4'	83"	(2) 10,000 lb. Torflex	235-75R-17.5
TBCT2220ET-MW	20,000	16'	6'	83"	(2) 10,000 lb. Torflex	235-75R-17.5
TBCT2420ET-MW	20,000	16'	8'	83"	(2) 10,000 lb. Torflex	235-75R-17.5

MW models come standard with 102" wide decks in front and behind fenders.

<b>Frame</b>	Angle Upper; 2" x 8" x 3/16" Lower Tube Frame
<b>Front Rail</b>	Solid Front Rail -- Flush Floor -- Pallet Fork Holder -- 83" Between Fenders
	Knife Edge Beavertail -- 14" Cushion Cylinder with Side Hand Valve
<b>Crossmembers</b>	3" Channel Crossmembers Every 12"
<b>Hitch</b>	2 5/16" Adjustable Coupler or Pintle Hitch (Pintle for 20K)
<b>Brakes</b>	Electric and Forward Self-Adjusting Brakes, Both Axles
<b>Fender</b>	1/4" Diamond Plate Steel Drive-over Fenders
<b>Jack</b>	10,000 lb. Heavy Duty Spring Loaded Jack
<b>Stake Pockets</b>	Yes
<b>D-Ring</b>	(4) -- at rear corners of stationary and rear corners of tilt
<b>Floor</b>	2 x 8 Treated Wood
<b>Safety Chain</b>	(2) 3/8 Safety Chains (1/2" chain for 20K)
	12-Volt Breakaway Kit With Full Charge Indicator, Switch & Battery
	Rubber Mounted Sealed LED Lights & Light Plug Holder
	Reflector Tape
<b>Finish</b>	Zinc Primed and Powder Coat Finish
<b>Optional</b>	Additional D-rings; Rub rail; Toolbox; Gooseneck; Spare Tire Mount

 DEXTER AXLE

 B-B TRAILERS  
BEHNKE ENTERPRISES, INC.

Manufactured by: Behnke Enterprises, Inc.

800 Ninth Ave. NW, Farley, IA 52046 - Ph. (563)744-3246 - Fax (563)744-9066

[www.behnkeenterprises.com](http://www.behnkeenterprises.com)