

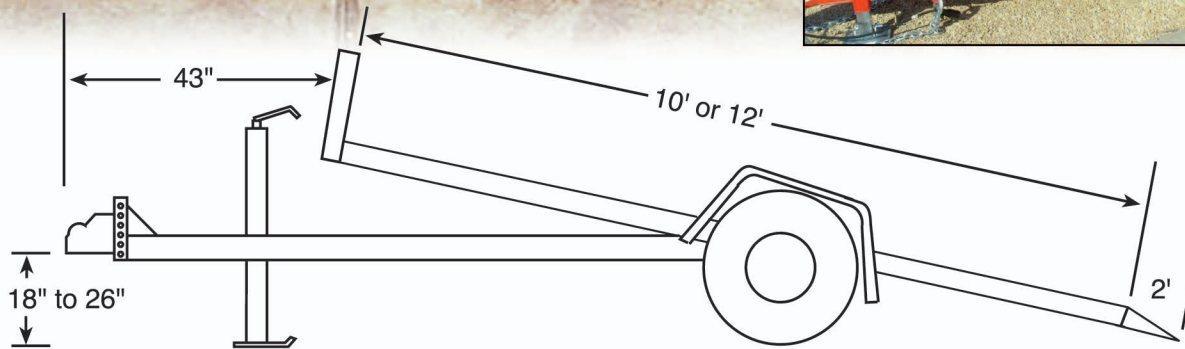

UTILITY

5,000 GVW • 6,000 GVW • 7,000 GVW

TILT BED



GVW	Frame	Axle	Tire
5,000 GVW	3" x 5" x 1/4" Angle	(1) 5,200 lb. Dexter E-Z Lube Axle, 4" Drop	ST225-75R-15" Radial Tire and Wheel
6,000 GVW	3" x 5" x 1/4" Angle	(1) 6,000 lb. Dexter E-Z Lube Axle, 4" Drop	ST235-80R-16D Radial Tire and Wheel
7,000 GVW	3" x 5" x 1/4" Angle	(1) 7,000 lb. Dexter E-Z Lube Axle, 4" Drop	ST235-80R-16E Radial Tire and Wheel

Standard Equipment

Brakes	Electric
	12" Front Rail (2" x 2" x 3/16 Angle)
	Heavy Duty Fenders
Hitch	2 5/16" Adjustable Coupler or Pintle Hitch
Jack	7,000 lb. Dropleg
Floor	2 x 8 Treated Wood Floor
	Stake Pockets
	(6) D-Rings
	12-Volt Breakaway Kit w/ Lockable Box, Switch and Battery
	Rubber Mounted Sealed Lights
	(2) 3/8 Safety Chains
	Cushion Cylinder with Needle Valve
Finish	Powder Coat Finish
Bed Length	10' or 12'
Bed Width	60", 72" or 81"

Powder Coating

All trailers manufactured by Behnke Enterprises, Inc. come complete with a powder coat finish. A powder coated finish makes products more durable, attractive and long-lasting. The powder coating process itself offers another advantage—it is environmentally friendly!



BEHNKE ENTERPRISES, INC.

800 Ninth Ave. NW, PO Box 357
Farley, IA 52046
Ph. (563)744-3246/Fax (563)744-9066
www.behnkeenterprises.com



BEHNKE ENTERPRISES, INC.