

Air Tilt Flatbed



Optional Triple Axle



Optional Air Ramps



Manufactured by:
Behnke Enterprises, Inc.
800 9th Ave. NW, Farley, IA 52046
Ph. (563)744-3246 ■ Fax (563)744-9066

FB8X31ATPT-40A

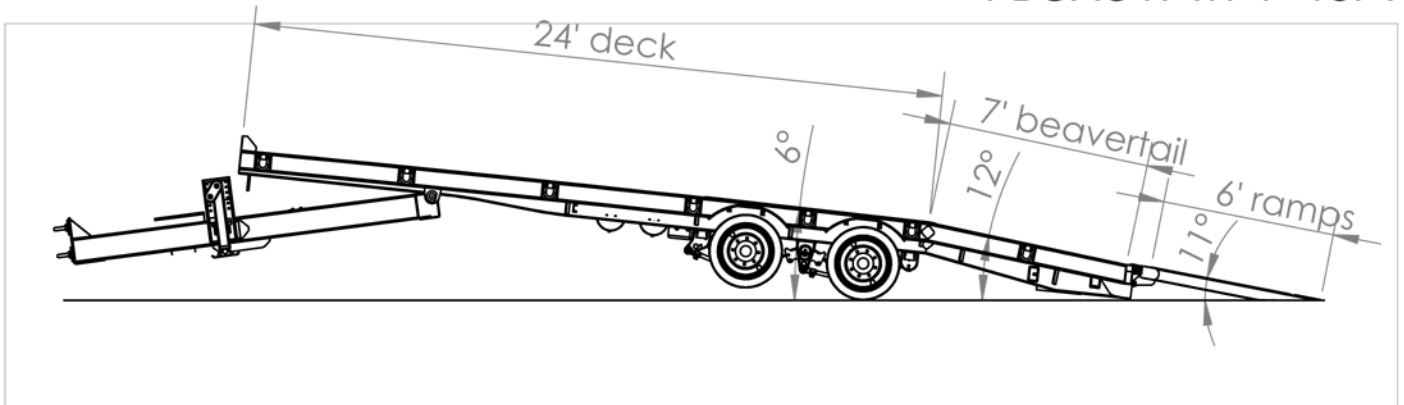

GVWR	40,000 lbs
Capacity	28,120 lbs + tongue weight
Weight	11,880 lbs (Includes air ramps)
General	24' bed w/7' beavertail and 6' air ramps, air bag tilting system, dual air brake chamber locking system, 102" wide
Frame	Tilt Frame: 1 Piece manufactured I-beam with 80K web and T1 flanges, 8" channel side rail, 35" unloaded deck height, headboard 6" above deck Lower Frame: 10 x 26# I-beam
Crossmembers	4" jr beams on 14" centers
Knee Braces	formed 3/16" Gr. 50 knee braces throughout frame
Jack	(2) Dual speed Semi-style landing gear (50,000 lb capacity)
Hitch	3" pintle eye (rated @ 90,000 lbs), adjustable from 18 1/2-30"
Safety Chains	Grade 70 transporter safety chain
Tie-Downs	(14) D-rings, 7 each side
Toolbox	Lockable toolbox in V-part of tongue
Axles	(1) 20,000 lb ABS axle, (1) 20,000 lb non-ABS axle (Dexter Brand axles)
Suspension	Dexter HDSS Spring
Tires	235/75R/17.5 tire and 8-bolt 17.5 x 6.75 rim
ABS	Bendix ABS
Finish and Paint	All trailers are pre-blasted, acid washed, zinc rich primer, and topped with powder coat
Electrical	all air and electric done after paint, DOT approved all sealed rubber mounted LED
Decking	Oak

*****NOTE: shown above w/air ramp option*****



Manufactured by:

Behnke Enterprises, Inc. ■ 800 9th Ave. NW ■ Farley, IA 52046 ■ Ph. (563)744-3246 ■ Fax (563)744-9066