

FLATBED TILT

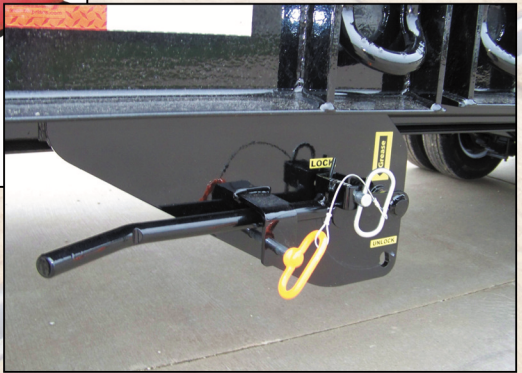

Manufactured by:
Behnke Enterprises, Inc. ■ 800 9th Ave. NW, Farley, IA 52046 ■ Ph. (563)744-3246 ■ Fax (563)744-9066
www.behnkeenterprises.com

FLATBED TILT

14,000 lb. GVW -- Pulltype

Model	Tilt Length	Stationary
GDFB8X22TPT	18'	4'
GDFB8X24TPT	18'	6'
GDFB8X26TPT	18'	8'

Standard Features

(2) 7,000 lb. Torflex Dexter Axles
(4) ST235-80R-16 Tire and Wheel
2 5/16 Coupler or Pintle Hitch

14,000 lb. GVW -- Gooseneck

Model	Tilt Length	Stationary
GDFB8X22TGN	18'	4'
GDFB8X24TGN	18'	6'
GDFB8X26TGN	18'	8'

Standard Features

(2) 7,000 lb. Torflex Dexter Axles
(4) ST235-80R-16 Tire and Wheel
8" Channel Gooseneck

(1) 12 x 12 x 48" Toolbox • (1) 10,000 lb. Heavy Duty Spring Loaded Jack • Dual Cushion Cylinders
 Rubber Mounted Sealed LED Lights • Stake Pockets & Rub Rail • 2 x 8 Treated Wood Floor • Mud Flaps
 (2) 3/8 Safety Chains • Light Plug Holder • Modular Wire Harness • Reflector Tape • Breakaway Kit
 Zinc Primed and Powder Coat Finish -- Black, Red, Blue, Gray, Yellowstone (standard colors)

Optional Axle Upgrade

8,000 lb.	215-75R-17.5 tire and wheel
-----------	-----------------------------

Triaxle	(7K) ST235-80R-16 tire and wheel
10,000 lb.	235-75R-17.5 tire and wheel

20,000 lb. GVW -- Pulltype

Model	Tilt Length	Stationary
FB8X28TPT	24'	4'
FB8X30TPT	24'	6'
FB8X32TPT	24'	8'
FB8X34TPT	24'	10'

Standard Features

(2) 10,000 lb. Heavy Duty Axles Oil Bath with Electric Brakes
(8) ST235-80R-16 Tire and Dual Wheel
2 5/16 Coupler or Pintle Hitch
(2) 12 x 12 x 48" Underbody Toolbox

20,000 lb. GVW -- Gooseneck

Model	Tilt Length	Stationary
FB8X28TGN	24'	4'
FB8X30TGN	24'	6'
FB8X32TGN	24'	8'
FB8X34TGN	24'	10'

Standard Features

(2) 10,000 lb. Heavy Duty Axles Oil Bath with Electric Brakes
(8) ST235-80R-16 Tire and Dual Wheel
8" Channel Gooseneck
(1) 12 x 12 x 48" Underbody Toolbox
(1) 12 x 12 x 36" Toolbox between uprights

Two Speed Dual Heavy Duty Spring Loaded Jack • Dual Cushion Cylinders
 (16) D-rings -- (8) Per Side • (2) 12 x 12 x 48" Toolboxes • Rubber Mounted Sealed LED Lights
 2 x 8 Treated Wood Floor • Mud Flaps • (2) 3/8 Safety Chains
 Light Plug Holder • Modular Wire Harness • Reflector Tape • Breakaway Kit
 Zinc Primed and Powder Coat Finish -- Black, Red, Blue, Gray, Yellowstone (standard colors)

Optional Axle Upgrade, Air Brake

10,000 lb.	ST235-80R-16 Tire and Dual Wheel
12,000 lb.	ST235-80R-16 Tire and Dual Wheel
15,000 lb.	215-75R-17.5 tire and dual wheel
20,000 lb.	235-75R-17.5 tire and dual wheel

Optional In Semi Style

60,000 to 80,000 Capacity

Optional Axle Upgrade, Electric Brake

12,000 lb.	ST235-80R-16 Tire and Dual Wheel
15,000 lb.	215-75R-17.5 tire and dual wheel



Manufactured by:

Behnke Enterprises, Inc. ■ 800 9th Ave. NW, Farley, IA 52046 ■ Ph. (563)744-3246 ■ Fax (563)744-9066

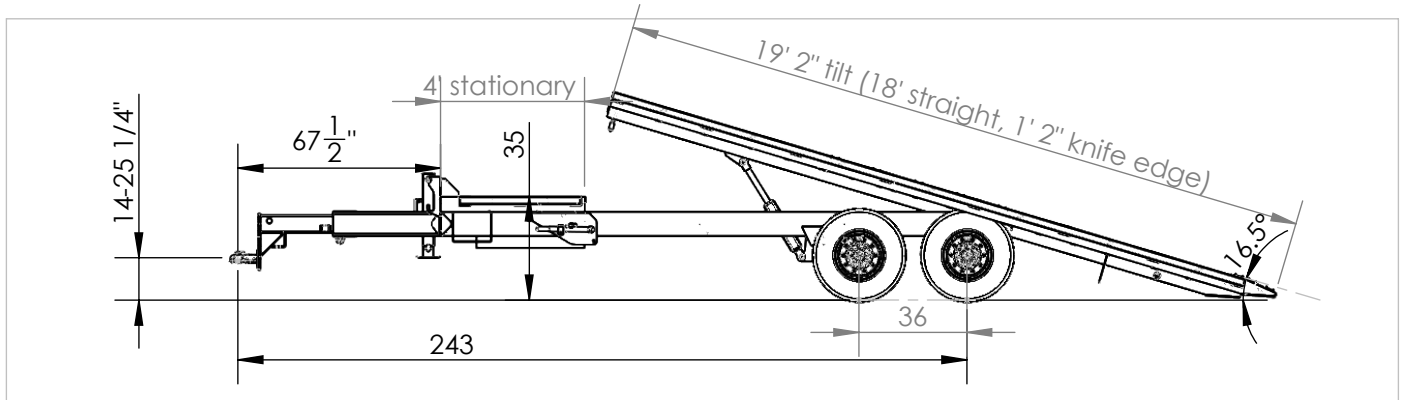

GVWR	14,000 lbs.
Capacity	9,220 lbs. + tongue weight
Weight	4,780 lbs.
General	4' stationary wood deck, 18' wood tilting deck w/knife edge beavertail, dual cushioned cylinders, 102" wide
Frame	Stationary Part: 8" channel, 5 x 3 x 1/4 angle side rail, 35" unloaded deck height, headboard 8" above deck Tilt Part: 8" channel frame, 5 x 3 x 1/4 angle side rail Beavertail: 1' sloped with 1" lip and traction bars
Crossmembers	3" channels on 16" centers
Jack	Dual speed jack (12K capacity)
Hitch	2 5/16" Demco E-Z latch coupler, adjustable 14-25 1/4"
Safety Chains	(2) 3/8" safety chains
Tie-Downs	stake pockets and rub rail
Axles	(2) 7K torflex Dexter axles
Brakes	Electric
Suspension	Torsion
Tire and Wheels	ST235-80R-16E Radial Tires and Wheel
Finish and Paint	All trailers are pre-blasted, acid washed, zinc rich primed, and topped with powder coat
Electrical	all air and electric done after paint, DOT approved all sealed rubber mounted LED
Decking	2 x 8 treated pine
Latch	Heavy duty pipe latch locking system w/safety pin (see photos)

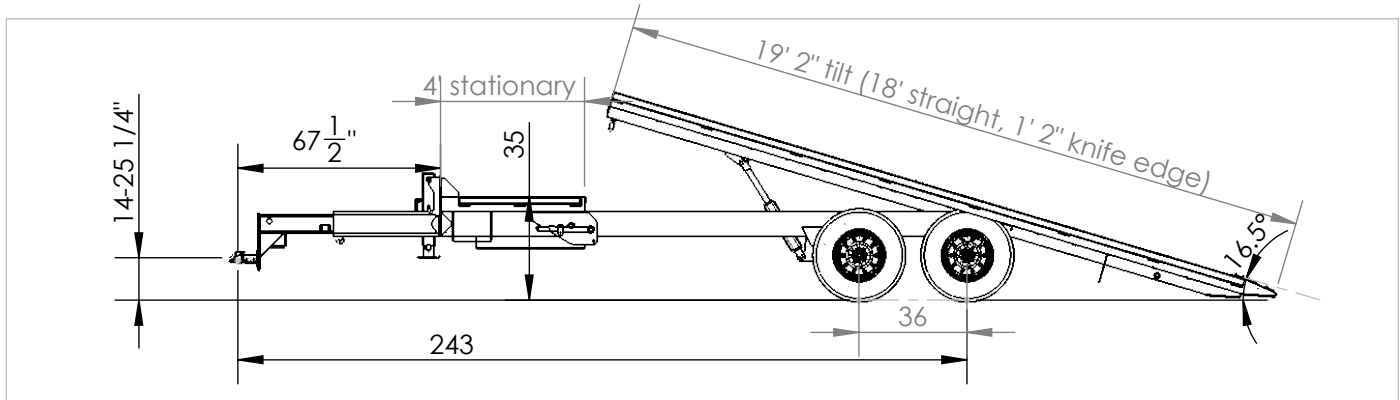

GVWR	16,000 lbs.
Capacity	10,780 lbs. + tongue weight
Weight	5,280 lbs.
General	4' stationary wood deck, 18' wood tilting deck w/knife edge beavertail, dual cushioned cylinders, 102" wide
Frame	Stationary Part: 8" channel, 5 x 3 x 1/4 angle side rail, 35" unloaded deck height, headboard 8" above deck Tilt Part: 8" channel frame, 5 x 3 x 1/4 angle side rail Beavertail: 1' sloped with 1" lip and traction bars
Crossmembers	3" channels on 16" centers
Jack	Dual speed jack (12K capacity)
Hitch	2 5/16" Demco E-Z latch coupler, adjustable 14-25 1/4"
Safety Chains	(2) 3/8" safety chains
Tie-Downs	stake pockets and rub rail
Axles	(2) 8K torflex Dexter axles
Brakes	Electric
Suspension	Torsion
Tire and Wheels	215/75R-17.5H Radial Tires and Wheel
Finish and Paint	All trailers are pre-blasted, acid washed, zinc rich primed, and topped with powder coat
Electrical	all air and electric done after paint, DOT approved all sealed rubber mounted LED
Decking	2 x 8 treated pine
Latch	Heavy duty pipe latch locking system w/safety pin (see photos)